

GIANPIETRO BENEDETTI
CHAIRMAN AND CEO
DANIELI

LO SVILUPPO DI ABS NELLA ZIU E LE NECESSITÀ INFRASTRUTTURALI

LA POLITICA INDUSTRIALE
DEL FRIULI VENEZIA GIULIA
ED IL RUOLO
DEI CONSORZI INDUSTRIALI
PROPOSTE DI MODIFICA
DELLA DISCIPLINA REGIONALE
12 MAGGIO 2014
CAMERA DI COMMERCIO DI UDINE



1. STEEL AND YOU
2. ABS TODAY
3. ABS INVESTMENTS 2013-2016
4. JUMBO BLOOM CASTING
5. HEAVY SECTIONS ROLLING
6. ABS INVESTMENTS AND
EXPECTED INFRASTRUCTURES



Ingots



Conticast sections



Forged products



Rolled products

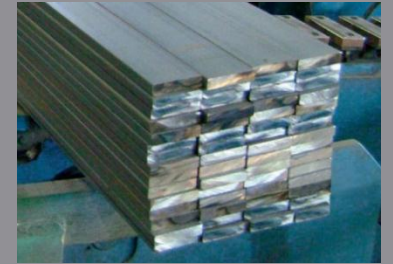

	FORGING OPEN-DIE FORGING	HOT & COLD FORMING	MACHINING
Casehardening steels	●	●	●
Hardening and tempering steels	●	●	●
Surface hardening steels		●	●
Microalloyed steels		●	●
Stainless steels	●	●	●
Bearing steels		●	●
Steels for petroleum sector	●	●	●
Spring steels			●
Steel for fasteners			●
Steels for tie rods			●
Steels with improved machinability	●	●	●
Globular sulphide shaped steels		●	●
Creep-resistant steels	●		●
Steels for grinding media			●

As-cast



As-forged



As-rolled



Shot blasted



Rough-rolled



Peeled-reeled



Ground



Turned

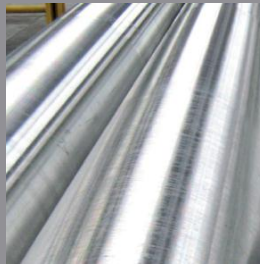

Chamfered

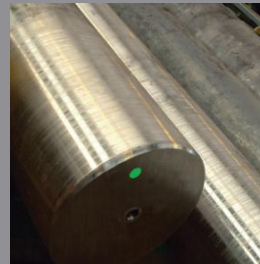

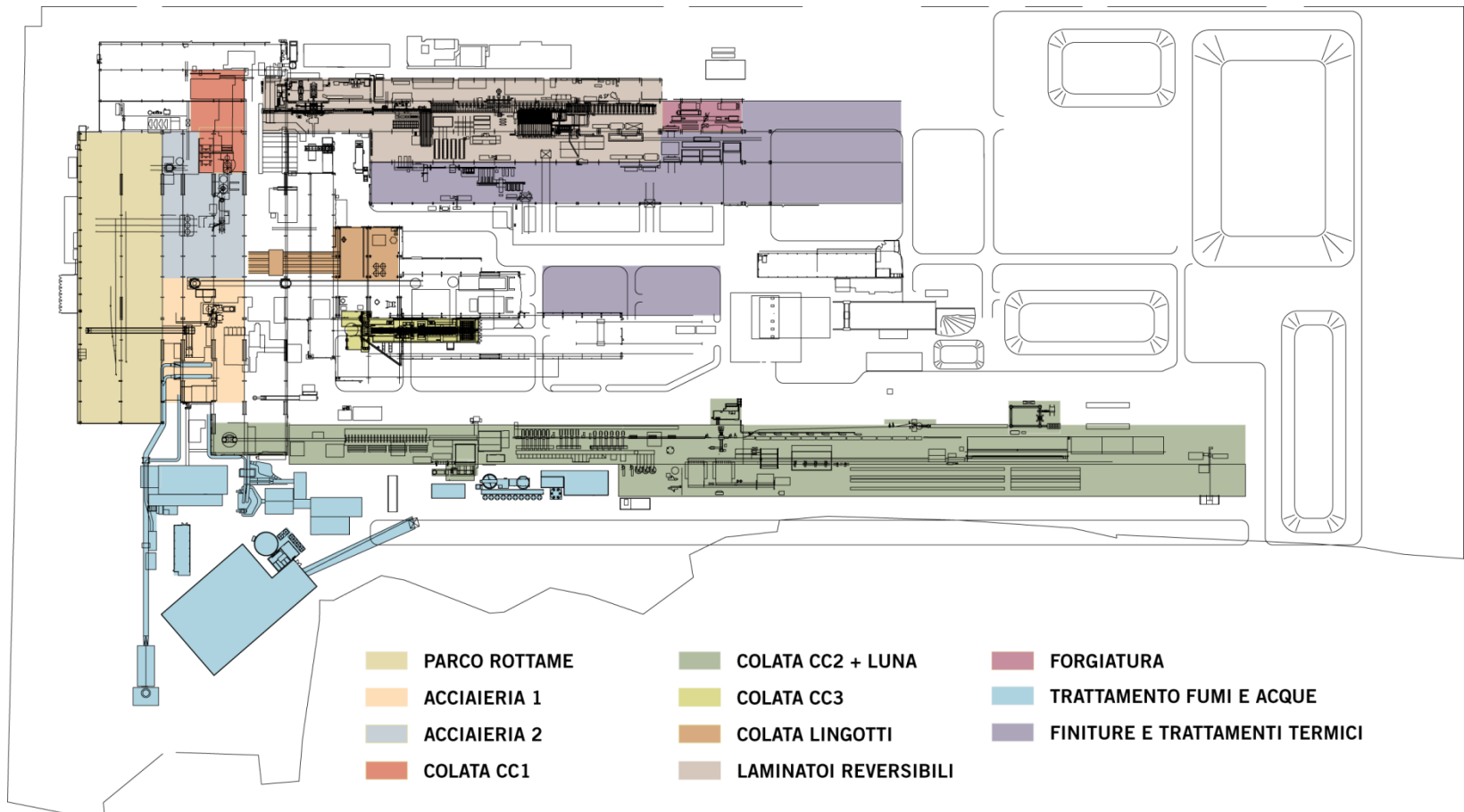

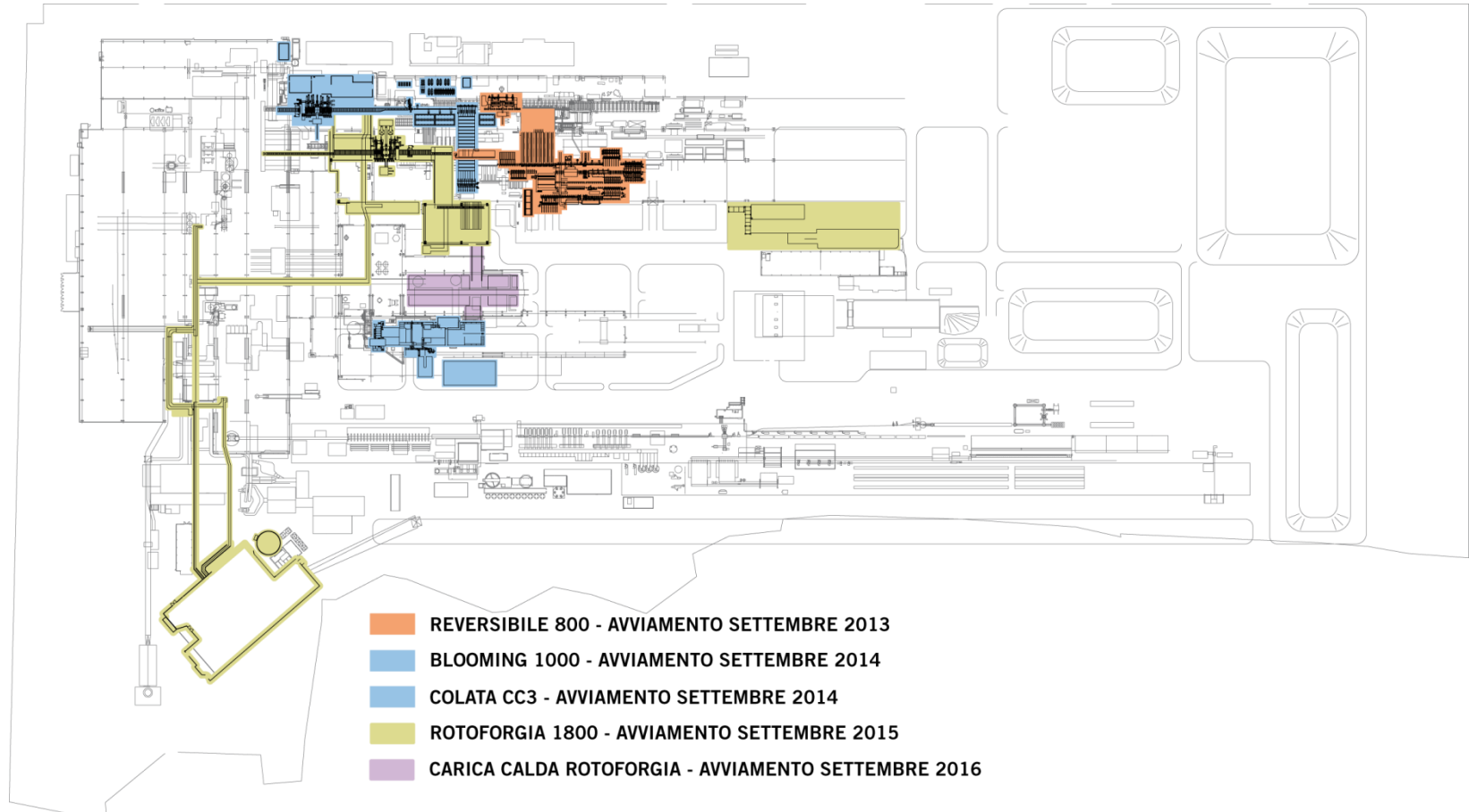

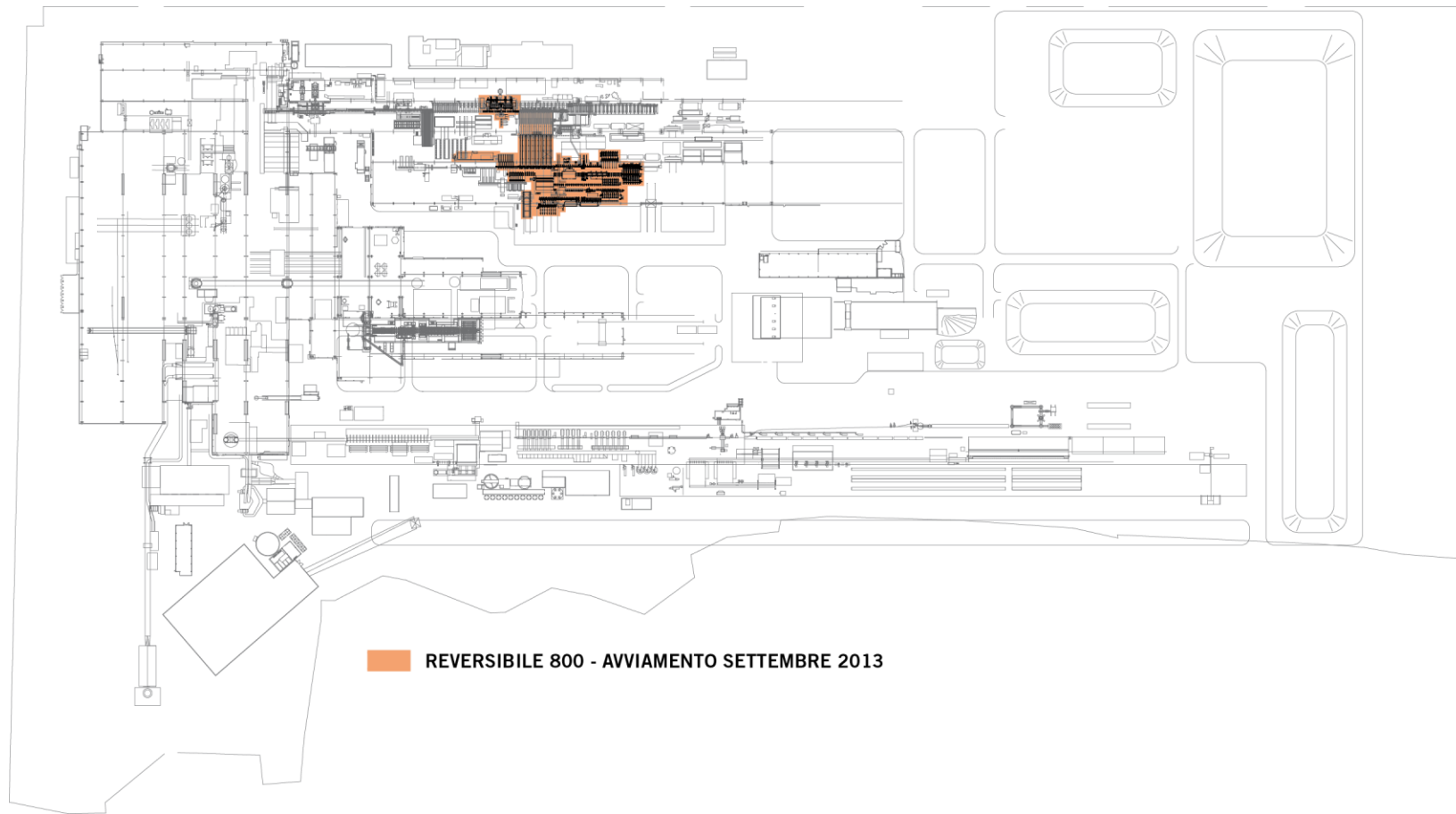

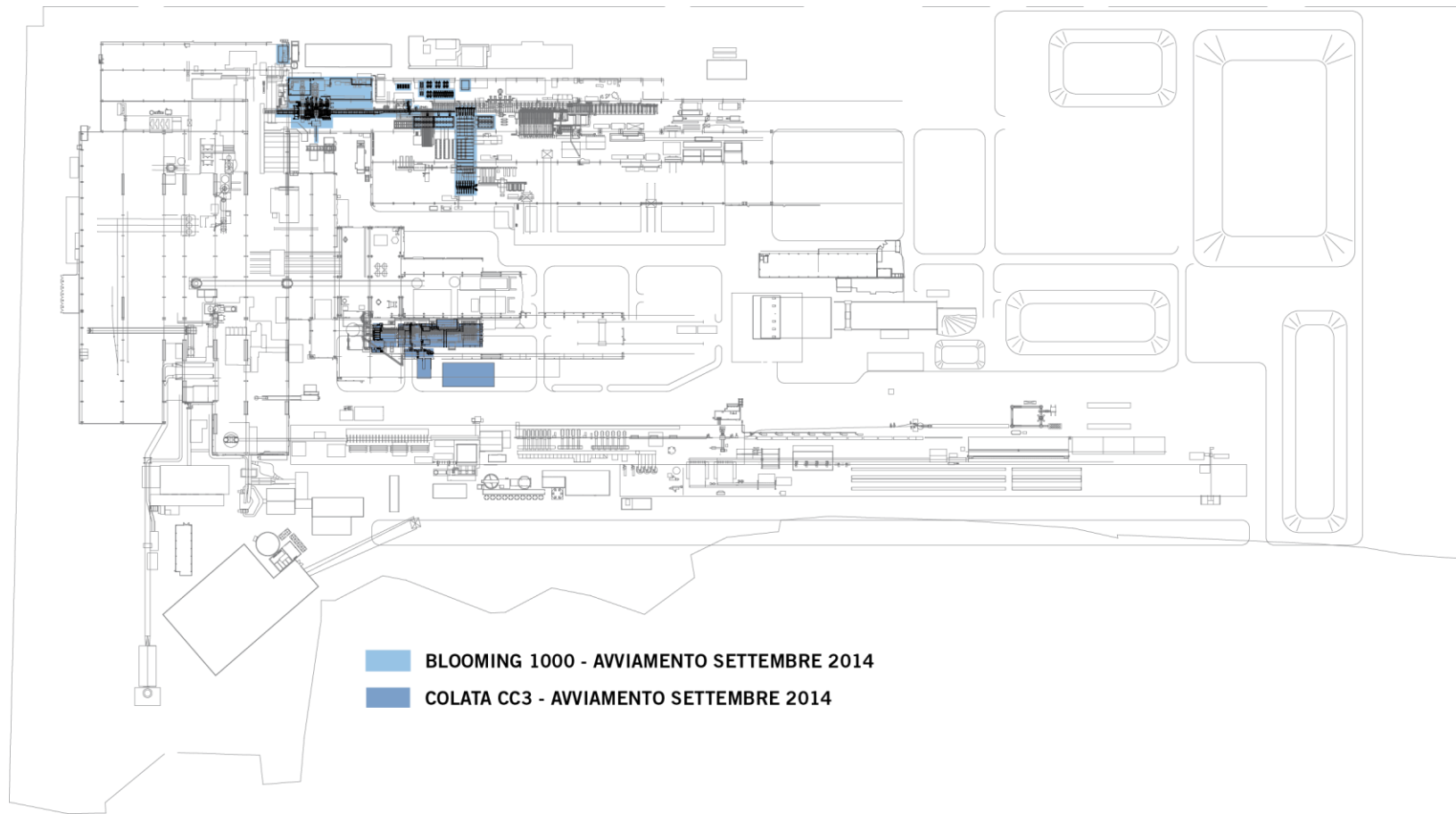

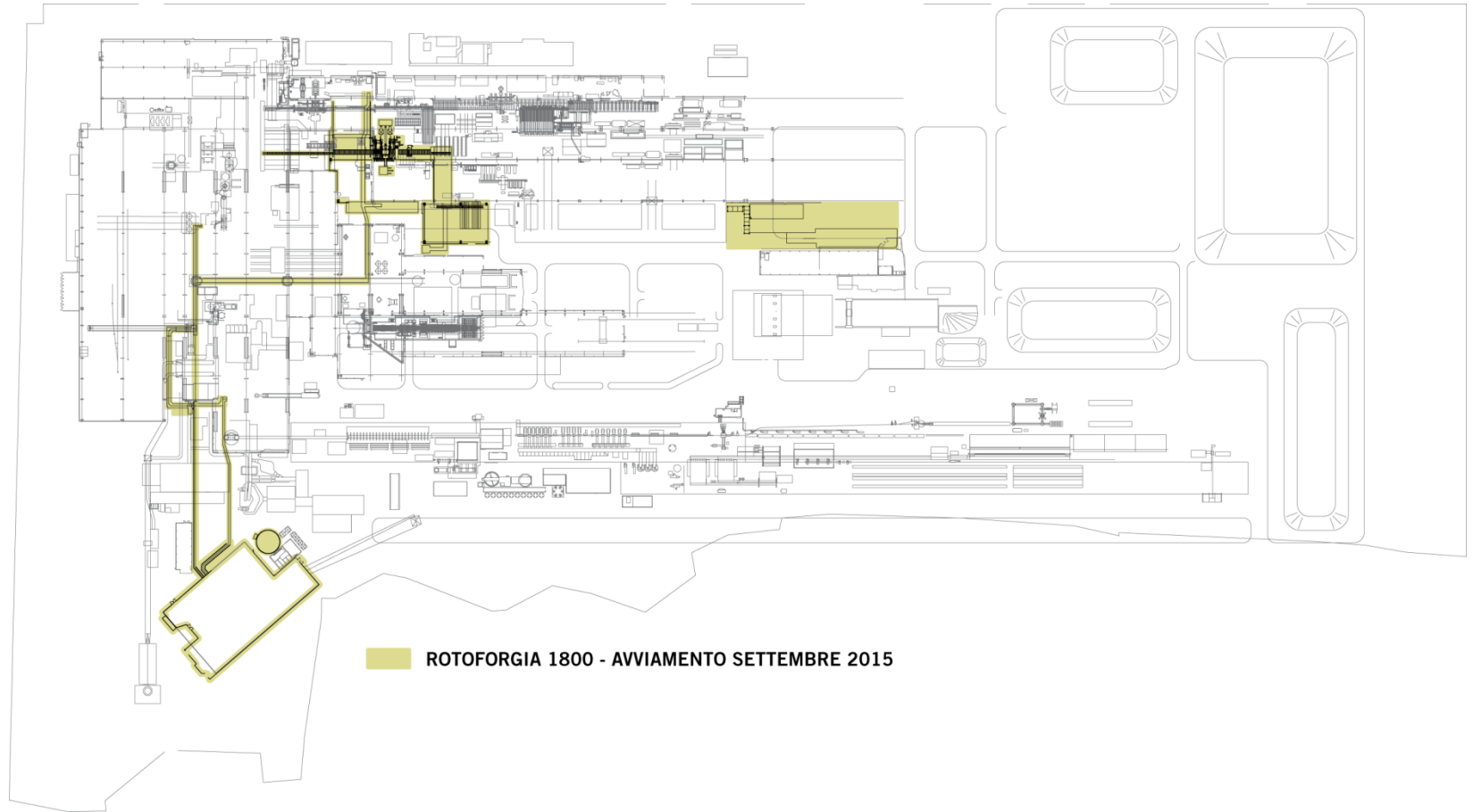

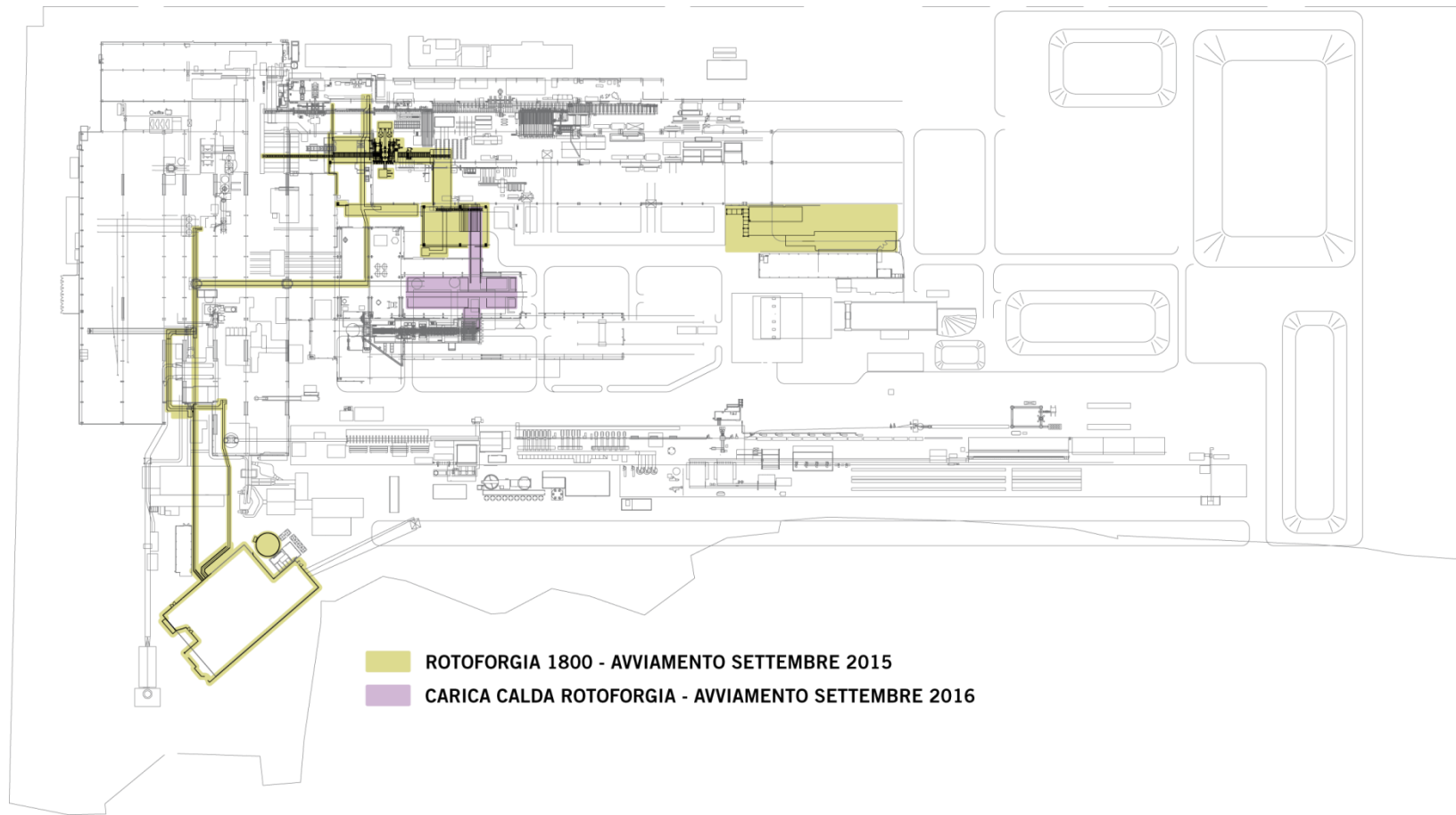







NEXT CHALLENGE SEPTEMBER 2014

850MM DIA BLOOMS

THE LARGEST DIAMETER CASTER IN THE WORLD

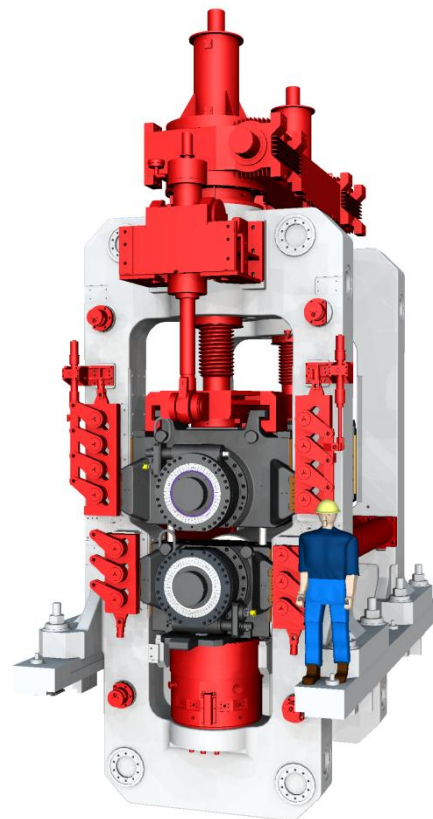
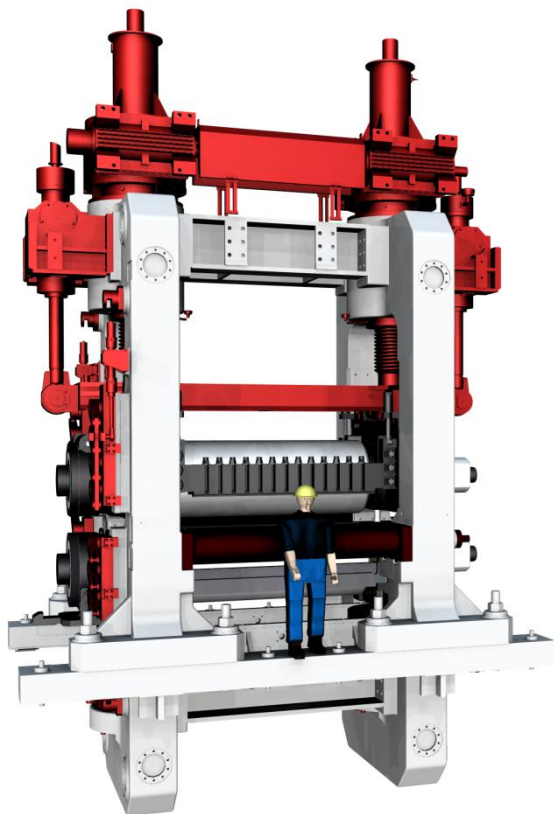

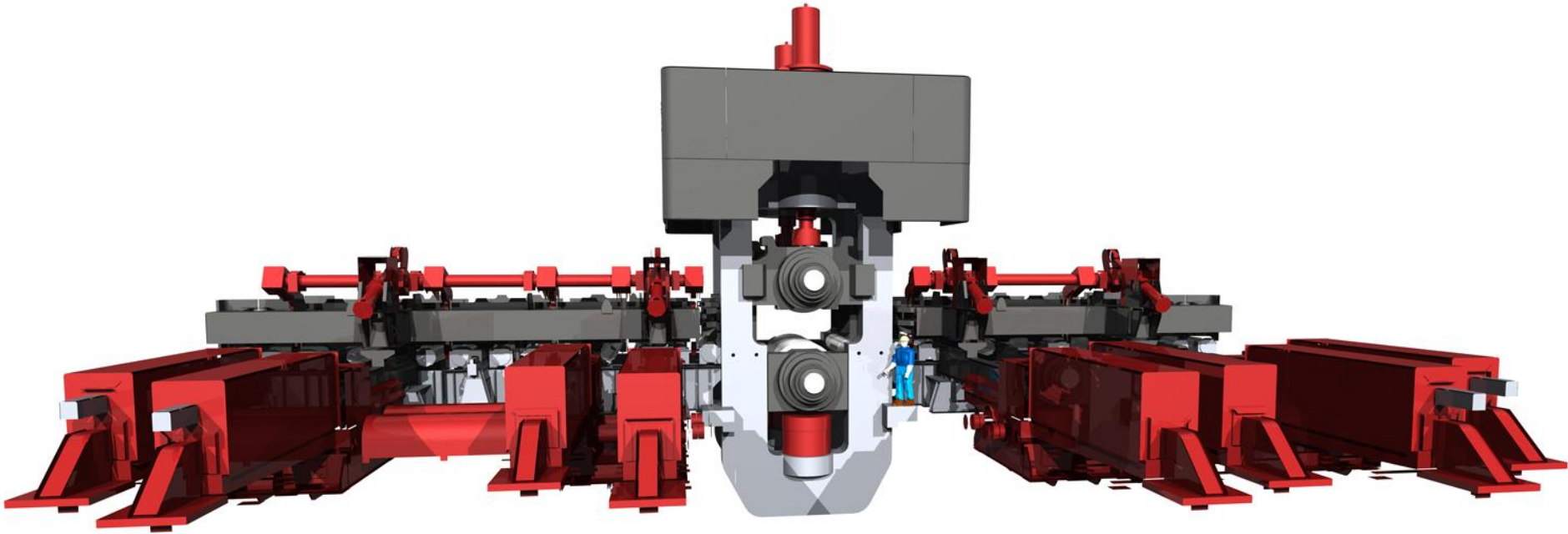

5 HEAVY SECTIONS ROLLING

ABS ROTOFORGIA

DANIELI



5 HEAVY SECTIONS ROLLING

ABS ROTOFORGIA

DANIELI



ABS fa la sua parte investendo 350 Milioni di Euro (2013-2018).

E' ovvio che un investimento di queste dimensioni richieda un ritorno ben definito.

L'investimento deciso da ABS tiene conto che entro il prossimo anno siano disponibili le seguenti infrastrutture:

LINEA ELETTRICA

**Per 250/280 MW a fronte dei 160 MW oggi disponibili
(Elettrodotto Redipuglia – Udine Sud)**

VIABILITA'

**Movimentazione per 1,5 Mtpy di materiali in arrivo
ed altri 1,5 Mtpy di materiali in partenza.**

**Si è quindi considerata un'ottimizzazione
del trasporto gomma / treno sulle principali direttrici
Francia / Germania con:**

(viabilità segue)

- > costruzione dello scalo ferroviario e centro intermodale ZIU**
- > connessione Udine Sud – Statale via Nazionale e miglioramento della viabilità in ZIU con rotonde adeguate ed altre attività necessarie.**

**ABS, con il via al maxi investimento,
dà per certo:**

- > che le realizzazioni di queste
infrastrutture
avvengano entro il 2015**
- > ed auspica che entro Maggio 2014
vengano definitivamente confermate.**

ABS: 1.5 MTPY OF SPECIAL STEELS PRODUCED IN A SUSTAINABLE WAY

